

NOTES:

- 1.MATERIAL:
  - MOLDING: LCP UL94 V-0
  - CONTACT:COPPER ALLOY.
  - PLATED GOLD ON CONTACT AREA,
  - G/F GOLD ON SOLDER AREA,
  - 50u" NICKEL PLATING OVER ALL.
- OUTER SHELL: SUS304,T=0.20±0.03mm  
50u" NICKEL PLATING OVER ALL.
- INNER SHELL:SUS304,T=0.30±0.03mm  
50u" NICKEL PLATING OVER ALL.
- LATCH:SUS301,T=0.15±0.03mm
- 2.MECHANICAL:
  - INSERTION: 5~20N.
  - EXTRACTION: 8~20N.
  - DURABILITY: 10000 CYCLES
- 3.ELECTRICAL:
  - CURRENT: 5A MAX FOR VBUS;
  - 1.25A FOR GND,0.25A FOR OTHER OTHER.
  - VOLTAGE: 20VDC MAX
  - WITHSTANDING VOLTAGE: 100V AC.
  - CONTACT RESISTANCE: 40mΩ MAX.
  - INSULATION RESISTANCE: 100MΩ MIN.
- 4.ENVIRONMENTAL
  - TEMPERATURE RANGE -40°C ~ +85°C



深圳市华宇创精密电子有限公司

TOLERANCE: X.X ±0.30 X.XX ±0.25 X.XXX ±0.15 X' ±2' X.X' ±0.5'	DRAWN BY : 陈一鸣	DATE : 2014-02-23	PART NAME: USB TYPE C 母座24P 板上 双贴双壳 垫高CL3.4 PH3.5 脚长1.5
	CHECKED BY: 马跃	DATE : 2014-02-23	PART NO. HVC763-USBC24-350
UNIT: mm [inch] SCALE:1:1 SIZE: A4	APPROVED BY: 邱敏	DATE : 2014-02-23	MOLD NO.
			DRAW NO: HVC-2607091422
			SHEET NO. 1 OF 1

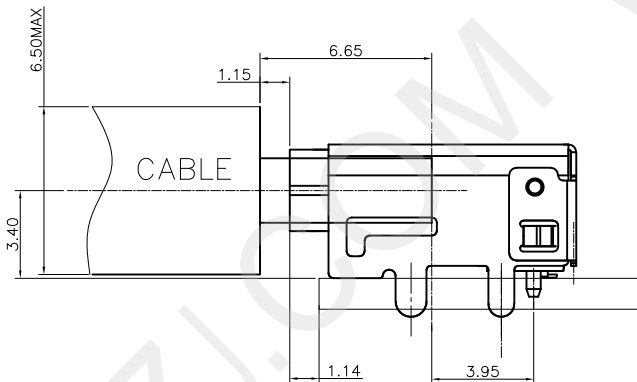
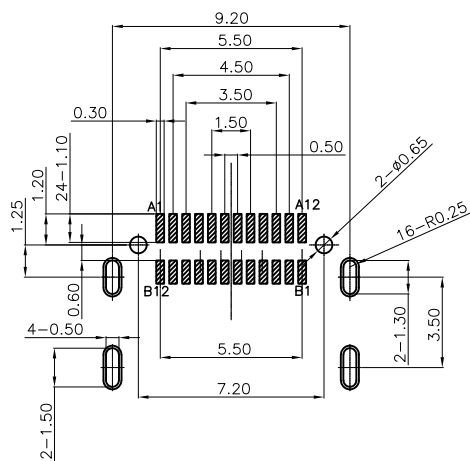

RECOMMENDED PCB LAYOUT (COMPONENT SIDE)

PCB THICKNESS: 1.60±0.05  
DEFAULT TOLERANCE: ±0.05

USB TYPE-C FULL-FEATURED RECEPTACLE INTERFACE PIN ASSIGNMENTS

PIN	Signal Name	Description	PIN	Signal Name	Description
A1	GND	Ground return	B12	GND	Ground return
A2	SSTXp1	Positive half of first SuperSpeed TX differential pair	B11	SSRXp1	Positive half of first SuperSpeed RX differential pair
A3	SSTXn1	Negative half of first SuperSpeed TX differential pair	B10	SSRXn1	Negative half of first SuperSpeed RX differential pair
A4	Vbus	Bus Power	B9	Vbus	Bus Power
A5	CC1	Configuration Channel	B8	SBU2	Sideband Use (SBU)
A6	Dp1	Positive half of the USB 2.0 differential pair-Position 1	B7	Dn2	Negative half of the USB 2.0 differential pair-Position 2
A7	Dn1	Negative half of the USB 2.0 differential pair-Position 1	B6	Dp2	Positive half of the USB 2.0 differential pair-Position 2
A8	SBU1	Sideband Use (SBU)	B5	CC2	Configuration Channel
A9	Vbus	Bus Power	B4	Vbus	Bus Power
A10	SSRXn2	Negative half of second SuperSpeed RX differential pair	B3	SSTXn2	Negative half of second SuperSpeed TX differential pair
A11	SSRXp2	Positive half of second SuperSpeed RX differential pair	B2	SSTXp2	Positive half of second SuperSpeed TX differential pair
A12	GND	Ground return	B1	GND	Ground return

8	UPPER CONTACT	12	COPPER ALLOY	PLATED GOLD ON CONTACT AREA, G/F GOLD ON SOLDER AREA, 50u" NICKEL PLATING OVER ALL.
7	LOWER CONTACT	12		
6	LOWER IM	1	THERMOPLASTIC UL 94V-0	COLOR: BLACK
5	UPPER IM	1	THERMOPLASTIC UL 94V-0	COLOR: BLACK
4	OVERMOLD	1	THERMOPLASTIC UL 94V-0	COLOR: BLACK
3	SHIELD PLATE	1	STAINLESS STEEL	CLEAN
2	INNER SHELL	1	STAINLESS STEEL	NICKEL PLATING OVER ALL.
1	OUTER SHELL	1	STAINLESS STEEL	NICKEL PLATING OVER ALL.
NO.	DESCRIPTION	QTY	MATERIAL	SPECIFICATION

**深圳市华宇创精密电子有限公司**

	TOLERANCE: X.X ±0.30 X.XX ±0.25 X.XXX ±0.15 X' ±2' X.X' ±0.5'	DRAWN BY : 陈一鸣	DATE : 2014-02-23	PART NAME: USB TYPE C 母座24P 板上 双贴双壳 垫高CL3.4 PH3.5 脚长1.5
		CHECKED BY: 马跃	DATE : 2014-02-23	PART NO. HVC763-USBC24-350
UNIT: mm [inch]	APPROVED BY: 邱敏	DATE : 2014-02-23	DRAW NO: HVC-2607091422	MOLD NO.
SCALE: 1:1 SIZE: A4			SHEET NO. 1 OF 1	

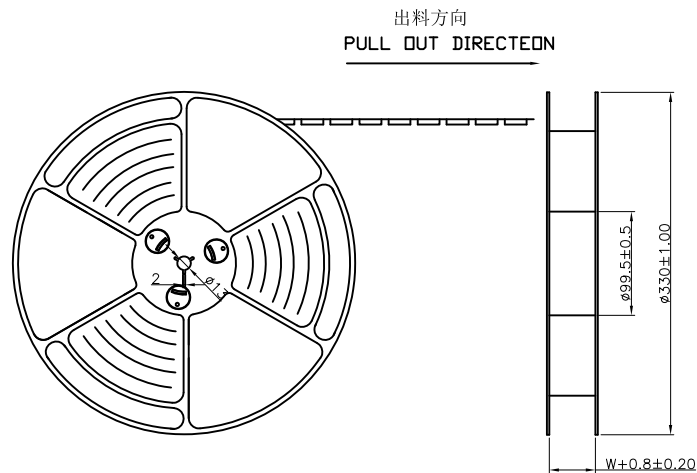

NOTES

1. 帶子引導長度  
LEAD TAPE LENGTH  
出料方向  
PULL OUT DIRECTEON

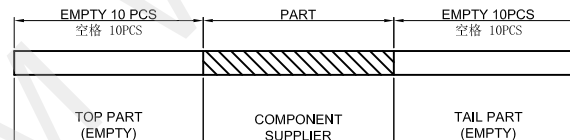

2. 出貨運輸過程中一定注意:  
THIS REQUIREMENT SHOULD BE APPLIED AT SHIPMENT:  
卷帶在運輸過程中不能散開  
PEELING OFF SHOULD NOT BE ALLOWED DURING TRANSPORTATION

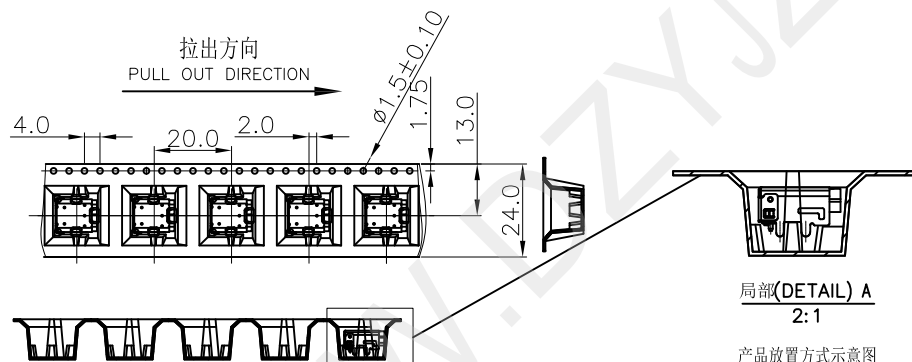

产品放置方式示意图  
PLACE PRODUCT AREA

 <b>深圳市华宇创精密电子有限公司</b>			
<b>TOLERANCE:</b> X.X ±0.30 X.XX ±0.25 X.XXX ±0.15 X.' ±2'    X.X' ±0.5'	<b>DRAWN BY :</b> 陈一鸣	<b>DATE :</b> 2014-02-23	<b>PART NAME:</b> 包装图
	<b>CHECKED BY:</b> 马跃	<b>DATE :</b> 2014-02-23	<b>PART NO.</b> 
<b>UNIT: mm [inch]</b> SCALE:1:1    SIZE: A4	<b>APPROVED BY:</b> 邱敏	<b>DATE :</b> 2014-02-23	<b>DRAW NO:</b> 
		<b>SHEET NO.</b> 1 OF 1	

Label pasting location (facing the back of the circular hole on the roll)

标签粘贴处 (朝卷带圆孔反面)

Location of label sticking (label)

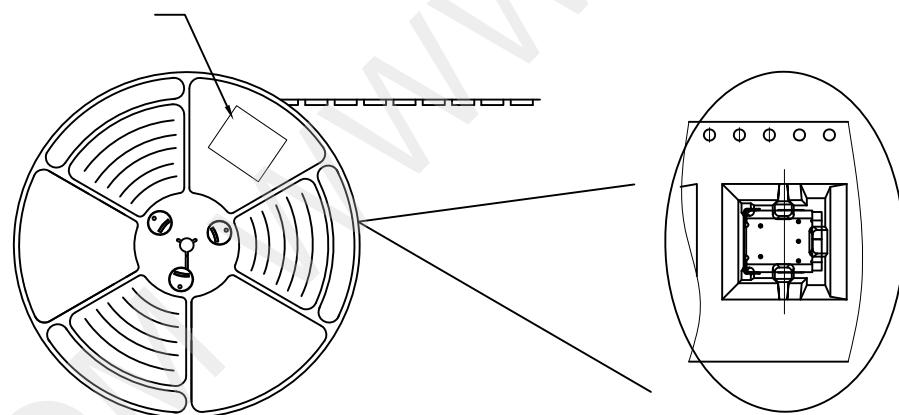
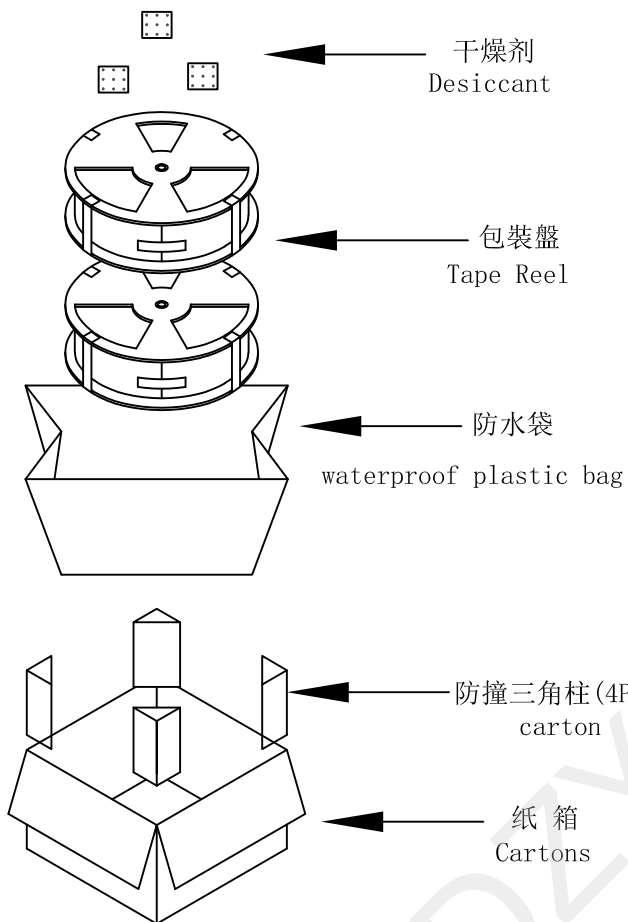

NOTE:

1. 每捲包裝數量及每箱裝箱數量如左下表格。  
Packing q'ty of each reel & carton as below table shown.
2. 以上膠帶覆蓋下包裝帶經包裝冷封方式封口  
The above tape under the cover of the package by the package of cold-sealed way sealed.
3. 將裝滿產品的卷盤放入紙箱并以膠帶封口  
Put reels in the carton and use adhesive tape to seal up.

产品料号 (PRODUCT No.)	包装数量 (PACKING CAPACITY)			重量 WEIGHT (Kg)		
	PCS/REEL	REELS/CARTON	PCS/CARTON	N.W./PCS	N.W./BOX	G.W./BOX
	400	10	4000	1.02	10.50	11.80

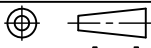
 <b>深圳市华宇创精密电子有限公司</b>			
TOLERANCE: X.X ±0.30 X.XX ±0.25 X.XXX ±0.15 X: ±2° X.X° ±0.5°	DRAWN BY : 陈一鸣	DATE : 2014-02-23	PART NAME: 包装图
 UNIT: mm [inch]	CHECKED BY: 马跃	DATE : 2014-02-23	PART NO. MOLD NO.
SCALE:1:1 SIZE: A4	APPROVED BY: 邱敏	DATE : 2014-02-23	DRAW NO: SHEET NO. 1 OF 1